



TECHNICAL DATA	ATIR I	ATIR II	ATIR III	TILTING ATIR I	TILTING ATIR II
Voltage	3 ~ 230/400 V 50Hz +PE				
Power kW	1.85	1.45	0.47	1.85	1.45
Water inlet Ø	1"	1"	1"	1"	1"
Water drain Ø	2"	2"	1" 1/2	2"	2"
Drum capacity l.	626	328	160	660	365
Net weight kg	174	122	92	220	161
Leaf vegetables loading capacity kg	16	9	5	16	9
Heavy vegetables loading capacity kg	70	35	20	70	35
Washing time minutes	2-3	2-3	2-3	2-3	2-3

DIMENSIONS	ATIR I	ATIR II	ATIR III	TILTING ATIR I	TILTING ATIR II
A	1570	1115	800	1570	1100
B	940	815	760	915	830
C	1150	1030	980	1135	1060
D	1260	995	825	1365	1090
E	-	-	-	1950	1500
F	-	-	-	1600	1390
G	-	-	-	785	700

LEADER IN VEGETABLES WASHING

The **Atir** brand stands for vegetable washers worldwide, because **Atir** was the first appliance designed to wash vegetables in restaurants, hotels, canteens, institutions, ready-to-eat fruit and vegetable processing centres and centralised kitchens.

Atir's exclusive washing system, featuring an adjustable whirl of constantly clean water that eliminates all dirt from even the most problematical vegetables, such as lettuce and spinach, in just three minutes,

guarantees water, energy and labour savings as well as an excellent hygiene.

What's more, **Atir** operates tirelessly, constantly and uniformly, from the first to the last wash, with perfect results every time. A guaranteed hygiene, also proven by bacteriological tests.

Atir, a full range of five models, with fixed and tilting drum, meets the production needs of kitchens from 200 to over 2,000 meals.

Lilma
LA SCIENZA DELLE GRANDI CUCINE



TECHNICAL DRAWINGS

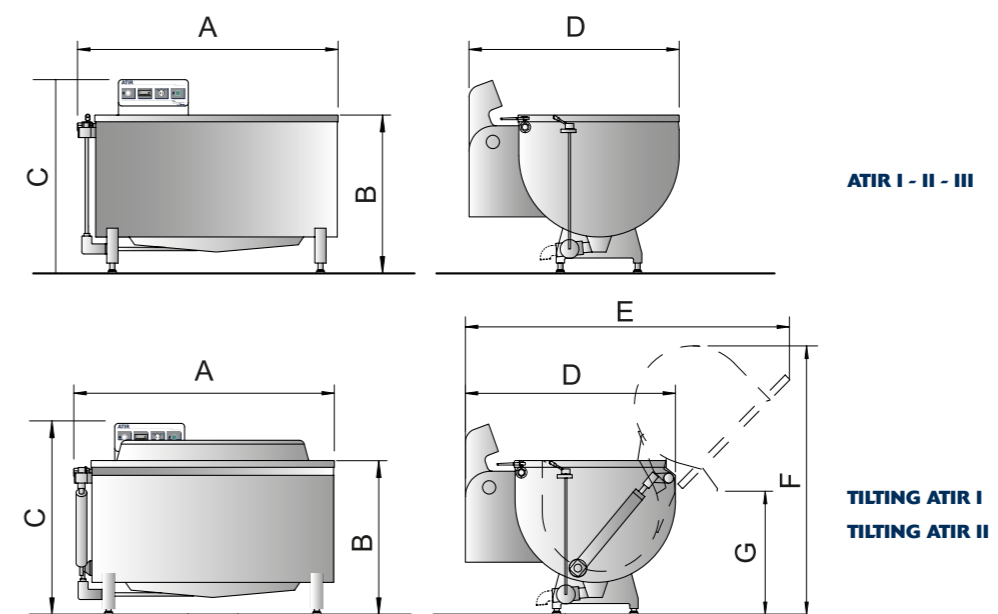

APPLIANCE MANUFACTURED IN ACCORDANCE WITH HARMONISED STANDARDS AND PROVIDED WITH THE CE MARKING

Company with EN ISO 9001 certified Quality Management System

NILMA S.p.A.

Via E. Zacconi, 24/A - 43122 Parma - Tel. +39.0521.785241 - Fax +39.0521.774642 - www.nilma.com • nilma@nilma.it
We reserve the right to make any changes or technical improvements considered necessary without notice



Lilma
LA SCIENZA DELLE GRANDI CUCINE

Washing with guaranteed hygiene and many economic and practical benefits

Really thorough washing

Washing vegetables properly is important above all from the health point of view. This is why Nilma has created **Atir**, a vegetable washer with a patented system that uses a pump to generate an adjustable whirl of constantly clean water, able to penetrate every cranny of vegetables and remove bacteria, soil, sand and pesticides. Bacteriological analyses confirm that after washing with **Atir**, the bacterial load has been removed.

... in constantly clean water

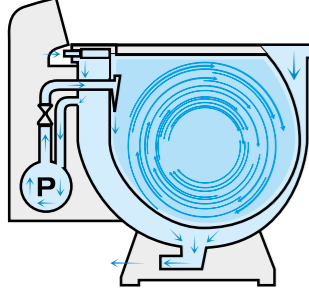

Optimal washing of vegetables needs the right input of fresh water. In **Atir**, the continual renewal of water, with constant levels, is achieved by adjusting the inlet and the drain. The washing water is drawn off from the top of the tank, near the water inlet. So **Atir** washes with clean water at all times.

Versatile and reliable

The exclusive intensity-adjustable washing system makes **Atir** ideal for washing the most widely varying foods: from lettuce to spinach and from carrots to celery, not to mention fruit, poultry, fish and shellfish. What's more, its extremely rugged stainless steel construction, simple mechanics and choice quality components guarantee the reliability that has made **Atir** world leader.

Automatic and user-friendly

Atir washes safely with no manual procedures: the user just adjusts the intensity of the whirlpool effect and sets the timer. What's more, the versions with tilting drum discharge the washed product into the trolley automatically.

And what about savings?

Washing vegetables manually, especially the leaf variety, takes a great expense of time compared to just three minutes with **Atir**. This saves precious time to be used in other kitchen tasks. And when it comes to energy costs, on average **Atir** uses just 4 Watts of electricity and less than half a litre of water to wash a kilogram of vegetables.



Atir III



TILTING Atir II



TILTING Atir I

Tilting drum versions



For even greater productivity, convenience and time savings, the **Atir I** and **II** models are also manufactured in the version with tilting drum. A hydraulic device lifts the washing drum and discharges the vegetables straight into the trolley in just 15 seconds.

Easy to clean

All **Atir** models feature an automatic washing of the internal tank.

At the start of each washing procedure, a multi-point spray sluices all dirt left inside the appliance out through the drain.



A full range

From the limited needs of restaurant or hotel kitchens to the tougher demands of those of hospitals or canteens, with its **five models** the **Atir** range always has the right solution for every production requirement.

CONSTRUCTION	
	AISI 304 stainless steel tank
	Polished AISI 304 stainless steel washing drum with holes on sides and bottom
	Adjustable feet
	Control panel, mechanical parts and electric pump protected by casings
SPECIFICATIONS	
FUNCTIONAL	Washing intensity regulator device
	Water drain regulator device
	Washing drum easily dismantlable for cleaning
	Automatic washing of the internal tank
	Atir I and II models feature the automatic tilting of the washing drum by means of a hydraulic device
	24V control panel equipped with: power light, working light, electronic washing timer, continuous/stop/timed washing selector, two-handed washing drum raising/lowering control (tilting version)
	IPX5 protection degree
Appliance manufactured in accordance with the EN 60335-2-64 Standards. Provided with the CE marking	

OPTIONS

Automatic water level regulator. With solenoid valve and electronic sensor, it maintains a constant water level in the washing drum

Analogue sanitizer dispenser. For use with the level regulator, it dispenses exactly the right quantity of disinfectant into the washing drum

Trolley with container to collect delicate vegetables or fruit. Consisting of a stainless steel frame with four castors and an AISI 304 stainless steel container having a depth of 250 mm.

Dimensions:
1660 x 800 x 750 mm (**TILTING Atir I**) or
1225 x 620 x 700 mm (**TILTING Atir II**)

Vegetable collection trolley. With frame and mesh basket made of AISI 304 stainless steel. Equipped with four castors.

Dimensions:
935 x 535 x 655 mm (**TILTING Atir I** and **TILTING Atir II**) or
610 x 510 x 590 mm (**Atir II – Atir III**)



Vegetable collection trolley