

DOUGH.O.MAT

Automatic pasta cooker

DOUGH.O.MAT

Automatic pasta cooker

Complete automation for perfect Italian cooking

Boil - but not too much



Over 98°, the pasta loses its starch and gluten and tends to overcook. The **Dough.O.Mat** is equipped with a device for temperature controlled cooking. This gives both quality and practical benefits, including: less foaming during cooking and energy savings of up to 20% compared to normal boiling pans.

1 kg pasta per 10 litres of water



This is the ideal ratio according to the best Italian tradition. In this amount of water, the pasta cooks evenly and with less starch: well-cooked, even consistency, no sticking.

Automatic stirring

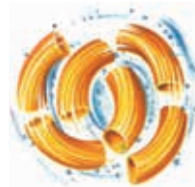

Cooking many kilos of pasta is far from simple: the pasta clumps together, adheres to itself, breaks and does not cook evenly.

The **Dough.O.Mat** is equipped with a hydrodynamic stirrer which operates while the pasta is cooking. The pasta is stirred by a vortex of water, at adjustable speed. This has the following advantages: completely automated cooking (no need for manual intervention while the pasta is cooking), the possibility to cook any type of pasta easily without damaging it, including tagliatelle and spaghetti, and even stuffed pastas like tortellini and soft pasta like gnocchi.

All this in a very reduced space

The **Dough.O.Mat** is available in six models, with one or two vats. Their large capacity enables them to cook from 200 to 2,400 plates of pasta an hour, in limited space, thanks to full automation and fast boiling times. Such performance is simply beyond the reach of normal boiling pans.

model	capacity	portions/hour*
C40 1 vat	7 kg	200-300
C40/2 2 vats	7+7 kg	400-600
C80 1 vat	20 kg	600-800
C80/2 2 vats	20+20 kg	1200-1600
C150 1 vat	40 kg	1200-1600
C300 1 vat	60 kg	1800-2400

* data for short format pasta or rice, portion size 100 g of uncooked product



TECHNOLOGY AT THE SERVICE OF TRADITION

In Italy, pasta is not simply a staple, but is a national specialty. Everybody knows that it must be cooked in abundant water and put in the pot when the water is boiling. But there are many secrets to a good plate of spaghetti. And very few people know them all.

- For example:
- cook at a controlled temperature so as not to lose the gluten and starch;
 - stir at the right speed for each type of pasta, so that it cooks evenly without sticking;
 - do not raise the lid as this changes the cooking temperature.

Nilma, in the design of the **Dough.O.Mat**, took all these factors into account and the result is a pasta cooker which combines revolutionary performance with the best gastronomic traditions.

A pasta cooker which is so perfect that you can even cook notoriously difficult dishes without problems, including: rice, spaghetti, tortellini and gnocchi.

And above all, a totally automatic pasta cooker which not only brings out the best in the pasta, but also improves the kitchen environment, the quality of your work, and is labour and energy saving.

Nilma

LA SCIENZA DELLE GRANDI CUCINE



TECHNICAL DRAWINGS

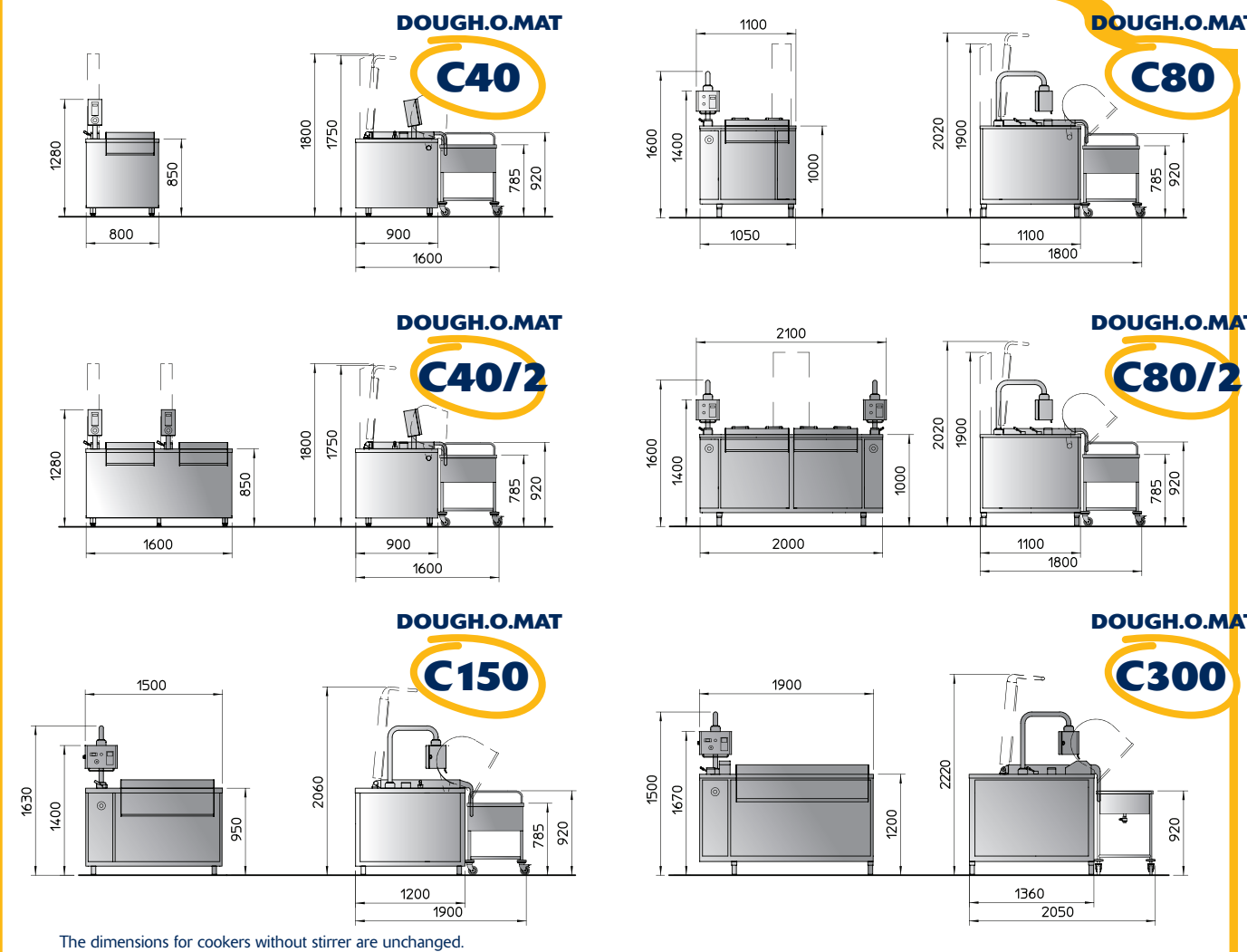

TECHNICAL DATA	C40		C40/2		C80		C80/2		C150		C300				
	Electricity	Gas	Electricity	Gas	Electricity	Gas	Electricity	Gas	Electricity	Gas	Electricity	Gas			
Vat capacity l	100		2x100		200		2 x 200		400		600				
Hot water Ø	3/4"		3/4"		3/4"		1"		1"		1 1/2"				
General drain Ø	1 1/2"		2 x 1 1/2"		2"		2 x 2"		2"		2"				
Steam Ø		3/4"		2 x 3/4"		1"		1 1/2"		1 1/2"		1 1/2"			
Pressure bar (kPa)		0,5(50)		0,5(50)		0,5(50)		0,5(50)		2(200)		2(200)			
Steam temperature °C		110		110		110		110		133		133			
Condense drain Ø		1/2"		2 x 1/2"		1/2"		1"		1/2"		1/2"			
Steam flow rate kg/h		50		100		80		160		150		260			
Gas Ø		1"		1 1/4"		3/4"		1 1/4"							
Caloric power (lower kW I ₂)		17		2 x 17		29/30		2 x 29/30							
Installed power kW	12,5	0,75	0,75	2x12,5	1,5	1,5	38	1,75	1,75	2 x 38	2x3,5	2x3,5	61,8	1,8	3,6
Voltage	3 ~ N 400 / 230 V 50Hz														
Weight kg	184	225	184	370	450	370	350	320	350	700	650	700	350	380	880



APPLIANCE CONSTRUCTED TO HARMONISED STANDARDS, CE MARKED

Company with UNI EN ISO 9001:2008 certified Quality System

NILMA S.p.A. - Via E. Zacconi, 24/A - 43122 Parma - Tel. +39.0521.785241 - Fax +39.0521.774642 - www.nilma.it • nilma@nilma.it
Nilma reserves the right to make any changes or technical improvements it considers necessary without notice.

Nilma
LA SCIENZA DELLE GRANDI CUCINE

DOUGH.O.MAT

Automatic pasta cooker

The surest way to cook large quantities, with big benefits and unbeatable results



Hygiene? Total

All surfaces in contact with the cooking water are in AISI 316 stainless steel for resistance to corrosion by salt. The cooking baskets and countervats are polished, with rounded corners, for easy cleaning. When cooking is finished, simply run the mixing pump to stir the water with additional "Keal" detergent, and even the most inaccessible areas are effectively self-cleaning.



Complete cooking programming

These allow busy chefs to get on with other jobs while the **Dough.O.Mat** cooks the pasta.

The programmer automatically controls the cook time and stirring modes (continuous-alternating).

On completion, the basket automatically lifts the pasta into the drain position. The chef needs only unload the pasta into the trolley.

Everything under control

On request, the **Dough.O.Mat** can be connected with the "Creative Control Machine Point" software which records not only the temperature/time values, but also the ingredients, quantities and steps required to cook any recipe.

Interactive use with the chef's PC allows you to track all ingredients and log all data. The "CCMP" software also runs fault-tracing on the Dough.O.Mat to highlight and log any alarm conditions.



ACCESSORIES

Trolley tank in insulated double-walled 18/10 stainless steel, complete with bottom shelf and four castor wheels, two with brakes.

C40 and C40/2
Dimensions: 740x620x912 h mm
Capacity: n 2 GN 1/1 h 200

C80 and C80/2
Dimensions: 1058x620x912 h mm
Capacity: n 3 GN 1/1 h 200

C150 and C300
Dimensions: 1875x620x800 h mm
Capacity: n 5 GN 1/1 h 200



CHARACTERISTICS	CONSTRUCTION
	<ul style="list-style-type: none"> Frame in 18/10 stainless steel tubing, on adjustable feet. Counter-vat and cooking baskets in AISI 316 stainless steel, external panelling, control panel, lids and flues in AISI 304 stainless steel. Self-balancing lid with integral handle. Tilting basket, perforated side walls and base. Cooking vat, insulated, with overflow device. Finishing: all parts in contact with product are polished. External panelling, lid and flue, fine satin finish.
FUNCTIONAL SPECIFICATIONS	<ul style="list-style-type: none"> Automatic basket tilt system controlled by electronic programmer. Hydrodynamic stirrer with stop/continuous/alternating modes. Indirect heating system with double jacket (except for gas heated versions). Stirrer automatically switches off when the basket is tilted. Vat with electronic water level control. Control panel mounted on mobile arm, IP55 rating. Thermostatically controlled water temperature, calibrated to 98°C. Automatic basket lift at the end of cycle. Cooking water drain device. Safety device switches off heating power if water is lacking in the vat. Independent basket and heating system operation (models C40/2 and C 80/2).

All models are available without stirrer on request

The work environment? Absolutely steam free

Dough.O.Mat requires no manual operation and can thus work with the lid closed, thus preventing steam from escaping and making the kitchen environment more humid.

Savings: energy... and labour!

The **Dough.O.Mat** heating system (gas, electricity, steam) is automatic and temperature controlled. This perfect thermostatic control - available on all versions - combined with the machine's effective insulation, gives considerable energy savings.

Dough.O.Mat operates fully automatically, with only a few manual tasks: setting the cook time and stirring parameters, loading the pasta, adding salt and, when cooking is completed, ending the pasta automatic unloading into the trolley. A single operator can handle these simple tasks, and while **Dough.O.Mat** is working, he can get on with other jobs.