

TVN 202

Continuous cycle cutter with infeed conveyor



VEGETABLES... AND MORE

Continuous cutting into slices, sticks, juliennes of every kind of vegetable, fruit, fish or other product has become a necessity for food processing firms and professional kitchens... and when there are large quantities of product to be cut and there can be no compromise on quality results, you need a machine that is versatile, fast and easy to use: cutter **TVN 202** is the best solution.

The product is fed in by an adjustable-speed conveyor and conveyed towards the knife set in a regular, continuous way by a pressing belt located above the inlet; the machine comes with a set of cutting disks to achieve the required thickness and shape.

The regular, clean cut results in impeccable presentation of

vegetables, leaf vegetables, fruit, even if juicy, and guarantees long product shelf-life.

The **TVN 202** cutter can also be effectively used in the fresh-cut sector, in line with the Atimatic washer, or for the preparation of seafood salads.

Once again Nilma has designed a technologically advanced machine that will enhance quality and speed up production in food processing firms and large kitchens.

Nilma

LA SCIENZA DELLE GRANDI CUCINE

TVN 202

Continuous cycle cutter
with infeed conveyor

FEATURES

CONSTRUCTION

- Full stainless steel 18/10 construction, parts in anticorodal material.
- Conveyor belts of food-grade PVC, width 120 mm.
- Length of product outlet door exceeds standard size.
- Discharge hopper equipped with water connection.
- Completely disassemblable for cleaning.

FUNCTIONS

- Control panel with: on/off control, power indicator, emergency stop, control for operation of infeed conveyor in both directions, digital display constantly showing machine operation status, function memorized for subsequent cycles, digital adjustment of cutting thickness, blade rotation display, functioning alarm light.
- Safety guards on infeed conveyor, on product discharge and on mechanical parts casings.
- Output rate: from 200 to 4000 Kg/h (depending on type of cut and type of product).



Dual blade disk



Julienne disk



Standard unit

Accessories

- Standard cutting unit, with two high-resistance treated stainless steel blades. Adjustable cutting thickness:
 - from 0.5 mm to 40 mm (standard knife set using two blades);
 - from 2 to 80 mm (standard knife set using one blade).
- Slicing disk with two blades, with cutting thickness adjustable from 1 to 10 mm.
- Slicing disk with fixed blades from 1 to 15 mm.
- Stick cutting disk 10 x 10 - 2 x 2 - 1,4 x 1,8 mm.
- Four stainless steel wheels: two fixed and two castors with brake.

Technical data

Power supply:	230 V single phase
Installed power:	kW 0,95
Weight:	Kg 143
Dimensions:	671x1324x1447 (h) mm
Dimensions of product infeed:	120 x 90 (h) mm.



Technical drawings

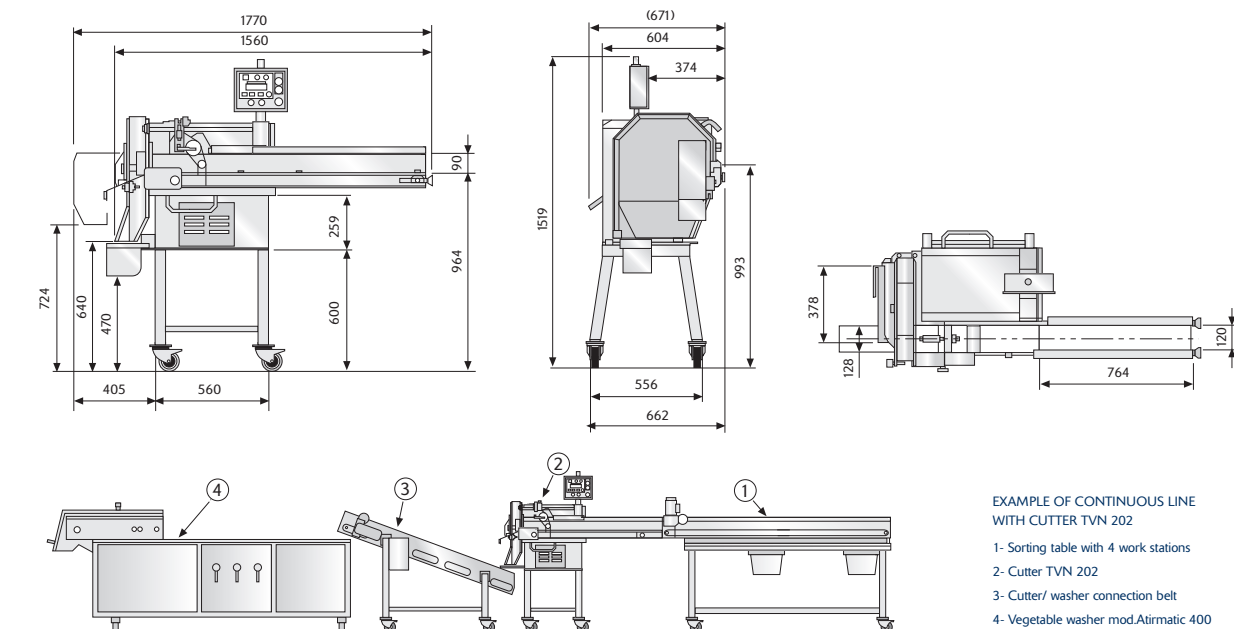

EXAMPLE OF CONTINUOUS LINE
WITH CUTTER TVN 202

- 1- Sorting table with 4 work stations
- 2- Cutter TVN 202
- 3- Cutter/ washer connection belt
- 4- Vegetable washer mod. Atirmatic 400



DEVICE MANUFACTURED TO
HARMONIZED STANDARDS,
WITH CE MARKING

Company with UNI ENI ISO 9001:2008
certified Quality System



LA SCIENZA DELLE GRANDI CUCINE

NILMA S.p.A. Via E. Zacconi, 24/A - 43100 Parma - Tel. +39.0521.785241 - Fax +39.0521.774642 - www.nilma.it • nilma@nilma.it

Nilma reserves all rights to make all changes and technical updates it considers necessary, without prior notice.