

MIX-MATIC 250/500 S

Universal cooker with mixer



HIGH PERFORMANCE AT FULL STEAM

Mix-Matic S is the ideal cooker for all types of sauces, Bolognese, bechamel, etc. Cooking temperature can be adjusted as required from very low up to a maximum of 165°C. This makes it possible to achieve the cooking results typically obtained with kettles, pans and braising pans. The kettle's hemispherical bottom and automatic mixing system ensure perfect mixage of the product during cooking.

The functioning of the mixing arm can be programmed for continuous or alternated operation with speed adjustable according to the recipe used. Basic and added ingredients are constantly stirred by the mixing device to prevent the heavier ingredients from falling to the

bottom of the kettle and thus assure perfectly homogeneous cooking.

Mix-Matic S is fully programmable and can be equipped with HACCP control and cooling system. It also enables rapid product discharge through a special valve or by automatic tilting of the cooking kettle.

Easy to clean, extremely sturdy and reliable, **Mix-Matic S** offers excellent performance in terms of both product output and product quality.

Mix-Matic S, a winning solution for the cooking needs of all food processing industries.

Nilma

LA SCIENZA DELLE GRANDI CUCINE

MIX-MATIC 250/500 S

Universal cooker with mixer

THE FEATURES

STRUCTURAL

- 1) Cooking kettle with hemispherical bottom, full stainless steel AISI 316 construction.
- 2) Frame, lid, panels and mixer in stainless steel AISI 304.
- 3) Lid with hydraulic lifting device and steam outlet.
- 4) Automatic mixing device, controlled by geared motor.
- 5) Hydraulic kettle tilting device.
- 6) Stainless steel AISI 304 discharge valve, with DN 50 connector, located on the bottom of the kettle.

FUNCTIONAL

- 1) Indirect steam heating. Operating pressure 8 bar.
- 2) Double adjustment device for cooking temperature.
- 3) Electromechanical control for hot and cold water inlet.
- 4) Automatic mixing device with variable speed.
- 5) Mixer with fluid-dynamic blades; easily removed for cleaning.
- 6) Safety device on kettle tilting and mixing system.
- 7) Jacket fitted with certified safety valve and adjustment pressure switch.
- 8) Low-voltage, analog control panel with digital display. Protection degree IP55.



ACCESSORIES

Stainless steel AISI 304 footbridge equipped with adjustable feet. Steps and floor surface made of antislip metal sheet.

Technical data

	MIX-MATIC 250 S	MIX-MATIC 500 S
Power connection	230/400V 3ph 50Hz+T	230/400V 3ph 50Hz+T
Installed power kW	1,1	4
Steam connection Ø	3/4"	1"
Pressure (Mpa)	0,8	0,8
Maximum loading capacity lt	250	500
Steam consumption kg/h	200	300

DIMENSIONS		
A	1714	2044
B	1534	1918
C	1847	2028
D	1173	1352
E (optional)	-	2644
F	462	503
G	1735	2131
H	2447	2926

Technical drawings

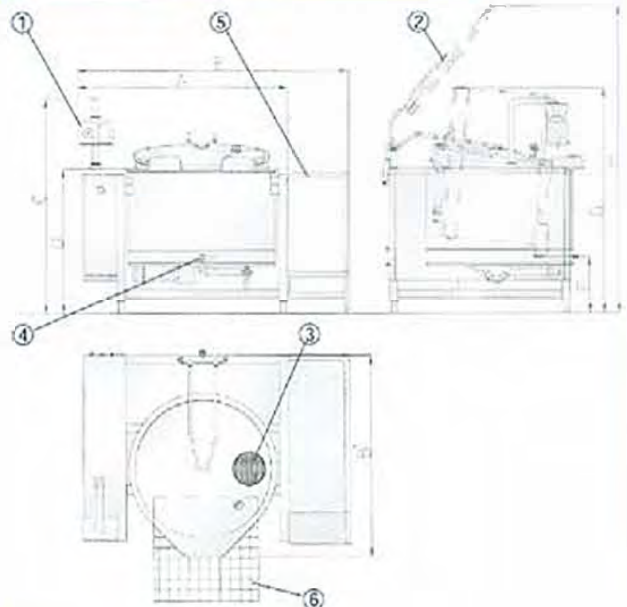

Legend

1) control panel. 2) lid, 3) steam outlet. 4) product discharge valve. 5) footbridge (optional). 6) discharge grid.

SPECIAL MODEL

- 1) Machine equipped with product cooking and cooling system (cook & chill).
Data available upon request.



Company with UNI EN ISO 9001:2008
certified Quality System

Wilma
LA SCIENZA DELLE GRANDI CUCINE

NILMA S.p.A. Via E. Zacconi, 24/A - 43100 Parma - Tel. +39.0521.785241 - Fax +39.0521.273050 - www.nilma.it • nilma@nilma.it

The factory reserves the right to make all the necessary alterations and technical improvements without notice